



# FORCE TORQUE SENSOR

DESIGNED FOR  UNIVERSAL ROBOTS

**GIVE YOUR ROBOT THE SENSE OF TOUCH**



## AUTOMATE FORCE SENSITIVE TASKS

Reliably perform:

- Precision part insertion
- Assembly and fabrication
- Automated product testing

## MADE FOR UNIVERSAL ROBOTS

Everything you'll need for a quick installation from hardware to software

## RELIABLE AND STABLE

FT 300 digital signal is not affected by noise

UR3



UR5



# TECHNICAL DATA

## FT 300

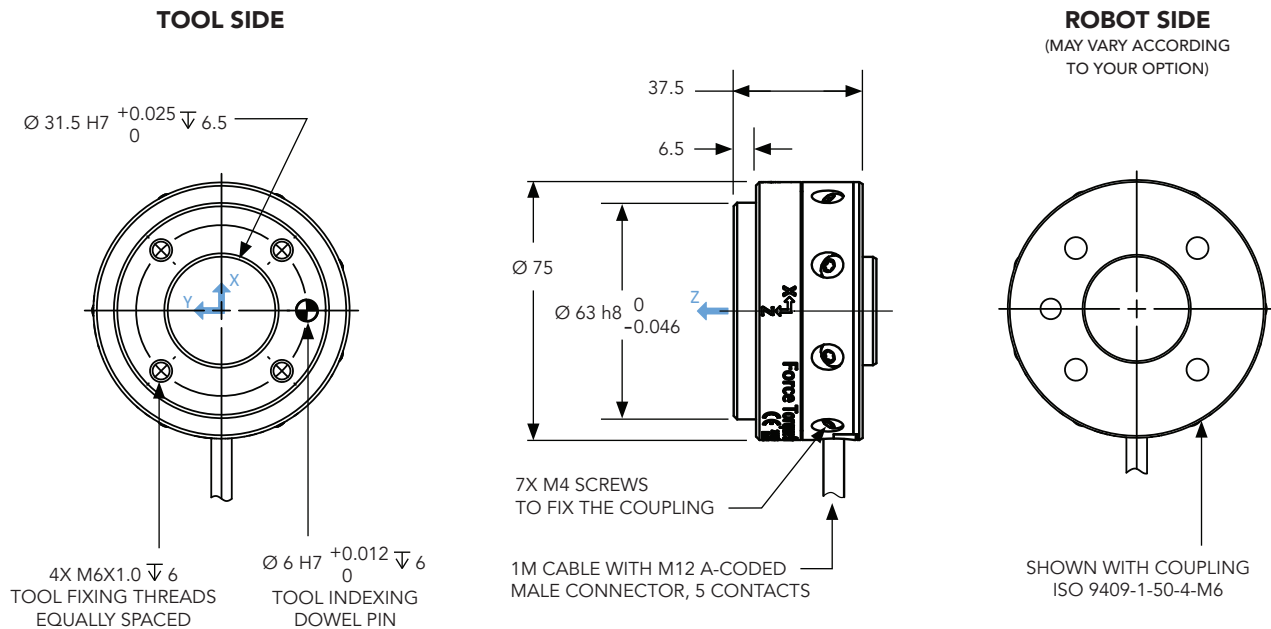

UNITS: mm

### SIGNAL SPECIFICATIONS

Measuring range	Fx, Fy, Fz	$\pm 300 \text{ N}$	
	Mx, My, Mz	$\pm 30 \text{ N}\cdot\text{m}$	
Signal noise	Fx, Fy	1.2 N	Noise is defined here as the standard deviation of each data for 1 second for a typical steady signal.
	Fz	0.5 N	
	Mx, My	0.02 N·m	
	Mz	0.03 N·m	
External noise sensitivity	All axes	Immune	Under normal operating conditions.
Data output rate		100 Hz	
Temperature compensation		15°C - 35°C	Temperature fluctuation is compensated for within this range. Signal quality may be affected outside of this range.

### MECHANICAL SPECIFICATIONS

Outside diameter	75 mm	
Thickness	37.5 mm	With Coupling ISO 9409-1-50-4-M6
Weight	300 g	With Coupling ISO 9409-1-50-4-M6
Overload capacity	500 %	Exceeding the overload capacity will permanently damage the sensor.

### ELECTRICAL SPECIFICATIONS

Nominal supply voltage	4.5-28 V DC	
Maximum power consumption	2 W	
Sensor electrical interface	RS-485, USB	Software packages available for Universal Robots, ROS, Linux and Windows.

robotiq.com  
T: 1.418.380.2788

fpeautomation.com  
T: 1.847.364.7455

Updated on February 5, 2016  
Specifications subject to change without notice